

CYPRESS CREEK BUSINESS PARK

Building 300 Suite 302

6555 N. Powerline Road

Ft. Lauderdale, FL 33309

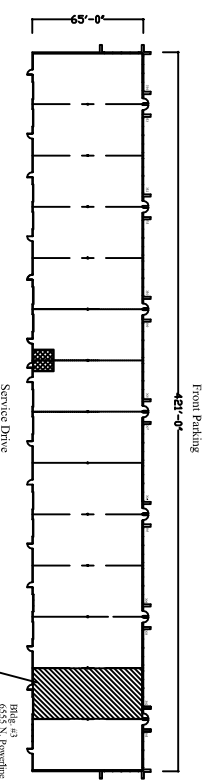
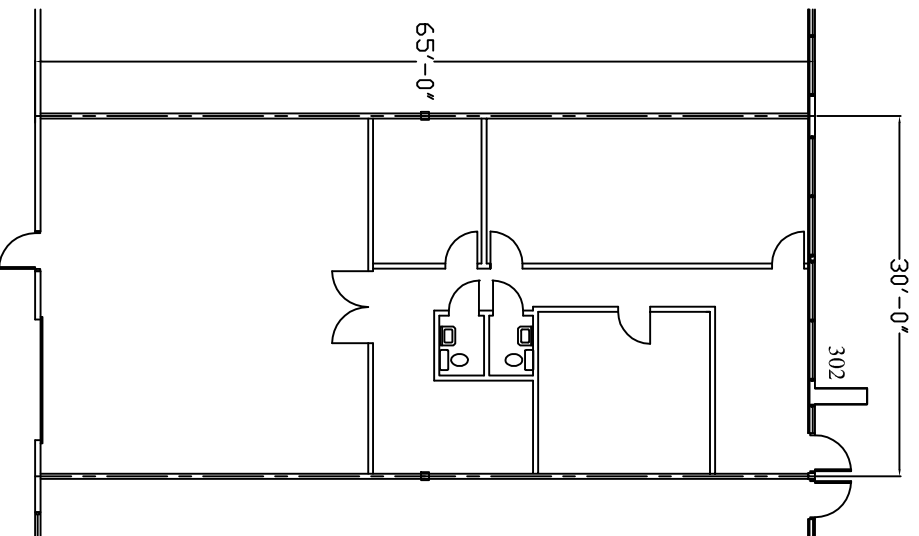

TENANT SPACE
1,950 SQ. FT.

OFFICE	1,950 SQ. FT.
WAREHOUSE	0 SQ. FT.
TOTAL AREA	1,950 SQ. FT.

FLOOR PLAN SUITE "302"

1/16" = 1'-0"

NORTH

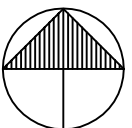

RIISING TIDE DEVELOPMENT, LLC

20445 Emerald Parkway Dr., Suite 220

Cleveland, Ohio 44135

(216) 458-0670

FAX (216) 458-0671

Date: 10/21/09